

Question Paper

Physics Multiple Correct (Maximum Marks: 32)

Question No. 1

One or More Options Correct Type

The question has multiple options out of which ONE or MORE is/are correct.

A small current element of length ' $d\ell$ ' and carrying current is placed at $(1, 1, 0)$ and is carrying current in ' $+z$ ' direction. If magnetic field at origin be \vec{B}_1 and at point $(2, 2, 0)$ be \vec{B}_2 then :

- A. $|\vec{B}_1| = |\vec{B}_2|$
- B. $\vec{B}_1 = -\vec{B}_2$
- C. $|\vec{B}_1| = |2\vec{B}_2|$
- D. $\vec{B}_1 = -2\vec{B}_2$

Question No. 2

One or More Options Correct Type

The question has multiple options out of which ONE or MORE is/are correct.

In a decay process A decays to B ,



Two graphs of number of nucli of A and B versus time is given then:

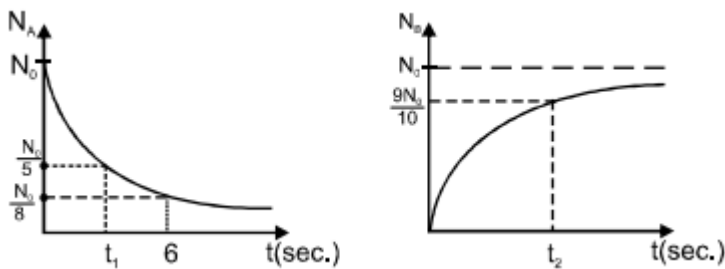

- A. $t_2 - t_1 = 4$
- B. $t_2 - t_1 = 2$
- C. $t_1 = 2\log_2 5$
- D. $t_2 = \log_2 100$

Question No. 3

One or More Options Correct Type

The question has multiple options out of which ONE or MORE is/are correct.

Figure shows an electric circuit contain four resistors of equal resistances 4Ω . Cells E_1, E_2, E_3 are ideal of unknown EMF whereas cell E_4 has some unknown internal resistance and EMF 4 V . It is found that current through EA, DH, FB and HE are 7 A , 6 A , 2 A and 5 A respectively as shown in figure.

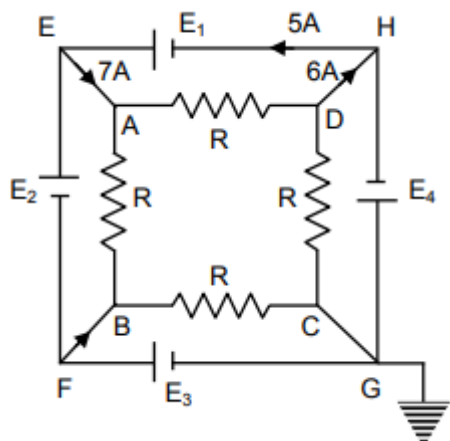

- A. Internal resistance of E_4 is 1Ω
- B. Current through DC is 0.5 A
- C. Current through AD is 5.5 A
- D. $E_2 = 6\text{ V}$

Question No. 4

One or More Options Correct Type

The question has multiple options out of which ONE or MORE is/are correct.

Choose the correct statement(s) regarding the photoelectric effect ?

- A. Photo current reverses its direction when the applied voltage is reduced further below the stopping potential.
- B. The photo current varies linearly with applied voltage
- C. The stopping potential remains unaffected if the intensity of the incident light is increased keeping frequency constant
- D. Saturation current does not depend on the intensity of incident light

Question No. 5

One or More Options Correct Type

The question has multiple options out of which ONE or MORE is/are correct.

Graph shows variation of source emf V and current i in a series RLC circuit, with time.

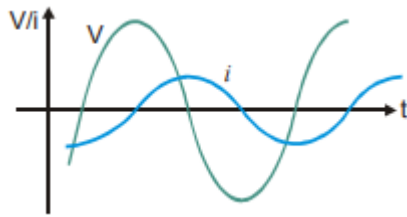

- A. The current leads the emf in the circuit.
- B. The circuit is more inductive than capacitive.
To increase the rate at which energy is transferred to the resistive load, L should be decreased.
- C. should be decreased.
- To increase the rate at which energy is transferred to the resistive load, L should be increased.
- D. should be increased.

Question No. 6

One or More Options Correct Type

The question has multiple options out of which ONE or MORE is/are correct.

Two identical strings each of mass m and length ℓ are connected on ceiling of a lift as shown in figure. Two wave pulses one at upper end of string-1 and other at lower end of string-2 are produced at simultaneously at $t = 0$ and lift also starts moving from ground upwards with constant acceleration g at same instant. Choose the correct option(s)

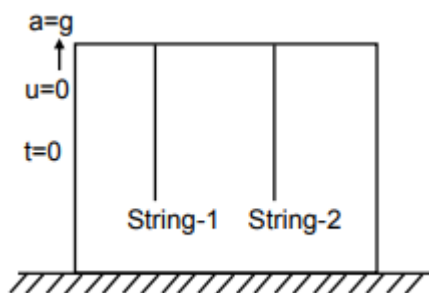

- A. Both the wave pulses will be at same horizontal level at $t = \sqrt{\frac{\ell}{2g}}$.
- B. Acceleration of pulse in string-1 with respect to ground is $2g$ downwards
- C. Acceleration of pulse in string-2 with respect to ground is $2g$ upwards
- D. height raised by lift when both pulses are at same horizontal level is $\frac{\ell}{4}$.

Question No. 7

One or More Options Correct Type

The question has multiple options out of which ONE or MORE is/are correct.

Four coherent sources of light of same intensity I_0 and in same phase are placed on a line Perpendicular to a large screen as shown in figure. The whole arrangement is placed in air. Assuming the net intensity at any point on screen is average (mean) of resultant intensities from both sides and point O lies on the screen and on the line joining the sources. D_1 measured from mid point of S_1 and S_2 and similarly D_2 measured from mid point of S_3 and S_4 . Choose the correct option(s) assuming that d_1 and d_2 are very small in comparison to D_1 and D_2 .

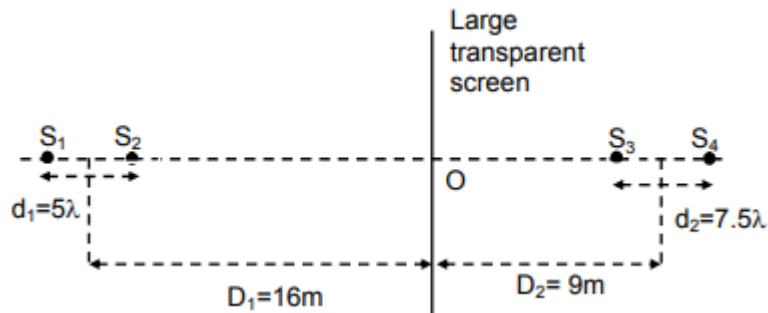

- A. The net intensity at point O is $2I_0$
- B. The shape of maxima on the screen is circular on both sides.
- C. The net intensity at a distance 12 m from O is $2I_0$.

The separation between maxima nearest to O due to sources on left side only and second maxima nearest to O due to sources on right side only is

- D. $\frac{21}{4} m$.

Question No. 8

One or More Options Correct Type

The question has multiple options out of which ONE or MORE is/are correct.

Two identical containers contains liquid of same mass m but different densities as shown in the figure given $\rho_1 > \rho_2$. P_1 and P_2 are pressures at the bottoms of the container-1 and container -2 respectively and F_1 and F_2 are the forces exerted by the liquid on the walls of container-1 and container -2 respectively. (Neglect the atmospheric pressure)

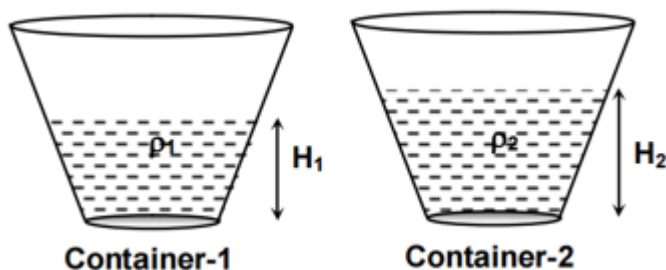

- A. $P_1 > P_2$
- B. $P_1 < P_2$
- C. $F_1 > F_2$
- D. $F_1 < F_2$

Physics Paragraph Type (Maximum Marks: 12)

Question No. 1

Only One Option Correct Type

Each question has multiple options out of which ONLY ONE is correct.

One mole of an ideal gas has an internal energy given by $U = U_0 + 2PV$, where P is the pressure and V the volume of the gas. U_0 is a constant. This gas undergoes the quasi-static cyclic process $ABCD$ as shown in the $U - V$ diagram.

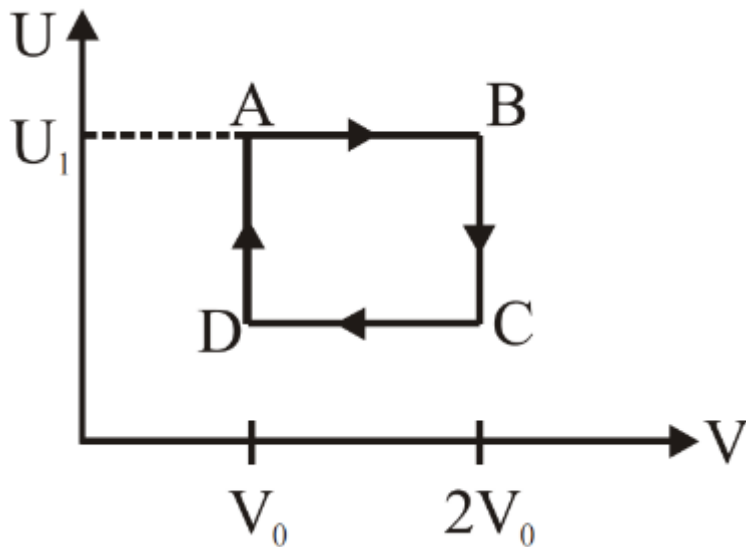

The molar heat capacity of the gas at constant pressure is :

- A. $2R$
- B. $3R$
- C. $\frac{5}{2}R$
- D. $4R$

Question No. 2

Only One Option Correct Type

Each question has multiple options out of which ONLY ONE is correct.

One mole of an ideal gas has an internal energy given by $U = U_0 + 2PV$, where P is the pressure and V the volume of the gas. U_0 is a constant. This gas undergoes the quasi-static cyclic process $ABCD$ as shown in the $U - V$ diagram.

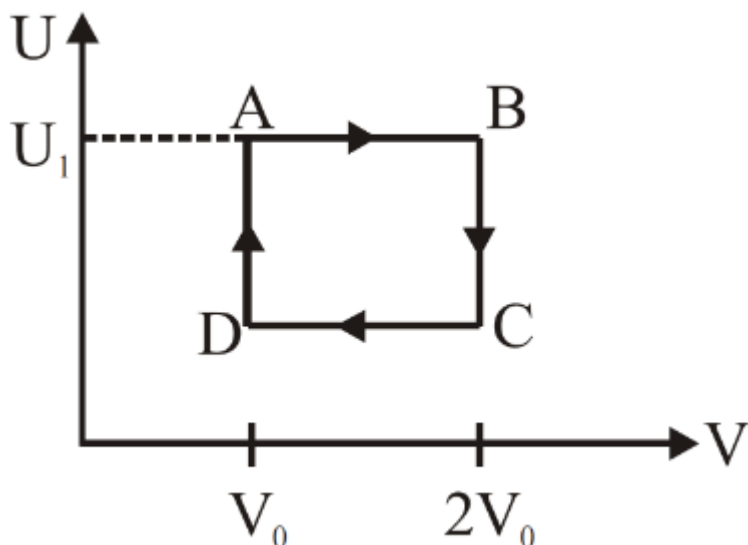

The work done by the ideal gas in the process AB is :

- A. zero
- B. $\frac{U_1 - U_0}{2}$
- C. $\frac{U_0 - U_1}{2}$
- D. $\frac{U_1 - U_0}{2} \log_e 2$

Question No. 3

Only One Option Correct Type

Each question has multiple options out of which ONLY ONE is correct.

A small orifice is created at the bottom of open half cylinder drum of length L and diameter D . The diameter of orifice is d ($d \ll L, d \ll D$). Water is initially filled upto height $H = \frac{D}{2}$.

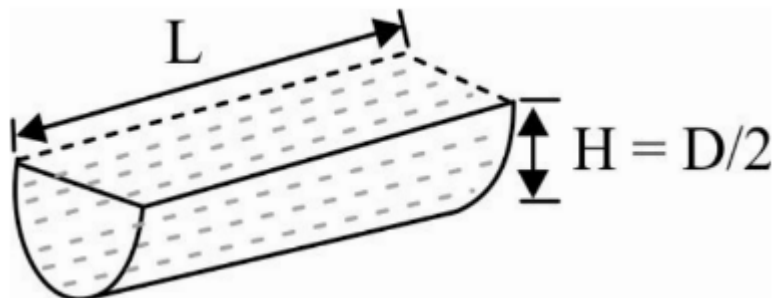

The initial velocity of efflux at $t = 0$, is :

- A. $\sqrt{2g(L - D)}$

- B. $2\sqrt{\frac{g(L-D)}{2}}$
- C. $\sqrt{2g(2L-D)}$
- D. \sqrt{gD}

Question No. 4

Only One Option Correct Type

Each question has multiple options out of which ONLY ONE is correct.

A small orifice is created at the bottom of open half cylinder drum of length L and diameter D . The diameter of orifice is d ($d \ll L, d \ll D$). Water is initially filled upto height $H = \frac{D}{2}$.

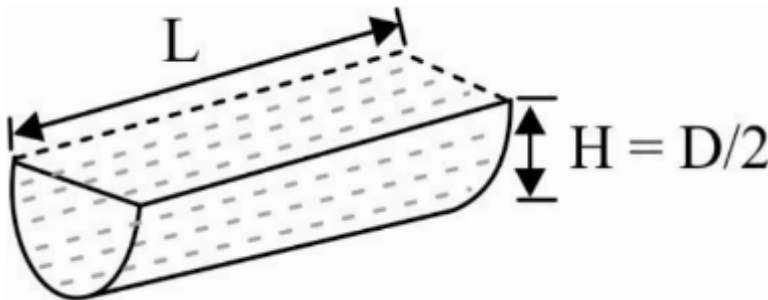

The time taken to get the drum empty completely is :

- A. $\frac{D^2}{d^2} \sqrt{\frac{L}{g}}$
- B. $\frac{4LD^{3/2}(2\sqrt{2}-1)}{3\pi d^2 \sqrt{g}}$
- C. $\frac{16D^2}{3\pi d^2} \sqrt{\frac{L}{g}}$
- D. None of these

Physics Numerical (Maximum Marks: 24)

Question No. 1

Numerical Type

The answer has to be filled into the input box provided below.

A particle is suspended by a light vertical inelastic string of length ℓ from a fixed support. At its equilibrium position it is projected horizontally with a speed $\sqrt{6g\ell}$. The ratio of the tension in the string when the string is in its horizontal position to that in the string when the particle is vertically above the point of support is $x : 1$. Find ' x '.

Question No. 2

Numerical Type

The answer has to be filled into the input box provided below.

Figure shows a particle of mass m attached with 4 identical springs each of spring constant K and each of which are initially in their natural length L . The gravitational force is neglected. If the mass is slightly displaced by distance x along a line perpendicular to the plane of the figure and released then the force acting on particle just when it is released is proportional to x^n , find n .

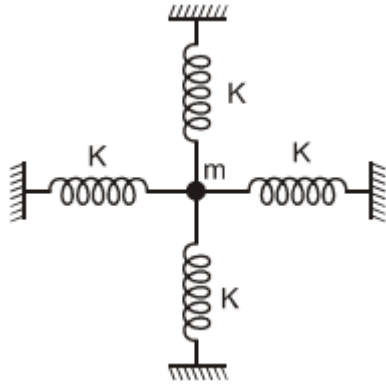

Question No. 3

Numerical Type

The answer has to be filled into the input box provided below.

The work function of a cathode is estimated using light of wavelength $310 \pm 1 \text{ nm}$. The stopping potential is measured to be $500 \pm 1 \text{ mv}$. $\frac{hc}{e} = 1240 \text{ vnm}$ (known precisely). What is the error e (in %) in work function. (roundoff to one decimal place)

Question No. 4

Numerical Type

The answer has to be filled into the input box provided below.

In the figure shown switch S_1 remains connected for a long time and the switch S_2 was open. Now the switch S_2 is also closed. Assuming $\varepsilon = 10 \text{ V}$ and $L = 1 \text{ H}$. The magnitude of rate of change of current in inductor (A/s) just after the switch S_2 is closed, is $\frac{30}{N}$. Find N

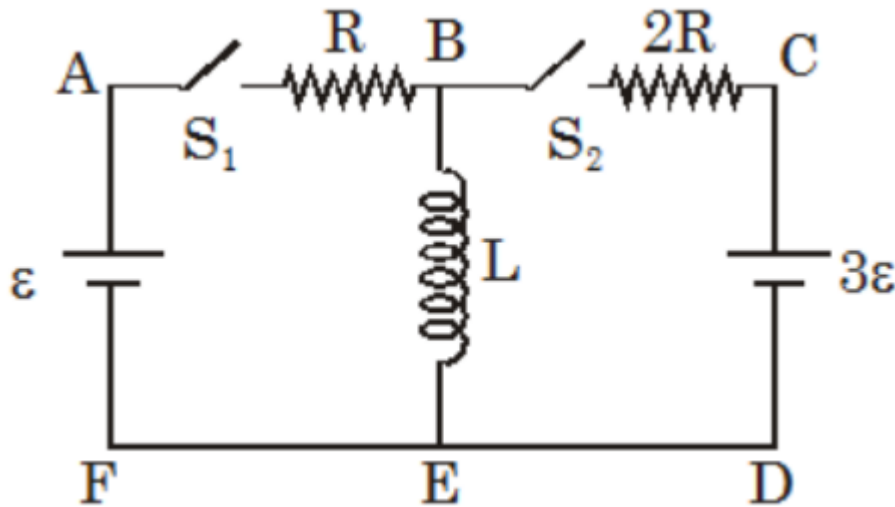

Question No. 5

Numerical Type

The answer has to be filled into the input box provided below.

Earth is rotating about its axis with angular speed ω_0 and average density of earth is ρ . It is proposed to make a space elevator by placing a long rod with uniform mass density extending from just above the surface for the earth out to a radius nR (R is radius of the earth). The rod can remain above the same point on the equator all time if, $n^2 + n = \lambda \frac{\pi G \rho}{\omega_0^2}$, where ρ is density of the earth. Find the value of λ .

Question No. 6

Numerical Type

The answer has to be filled into the input box provided below.

A monkey of mass m is sitting on a platform of mass M . Monkey can jump with a velocity of 5 m/s making an angle 37° with the horizontal with respect to platform. To jump the monkey 1 meter with respect to the ground. Find out the value of m/M

Chemistry Multiple Correct (Maximum Marks: 32)

Question No. 1

One or More Options Correct Type

The question has multiple options out of which ONE or MORE is/are correct.

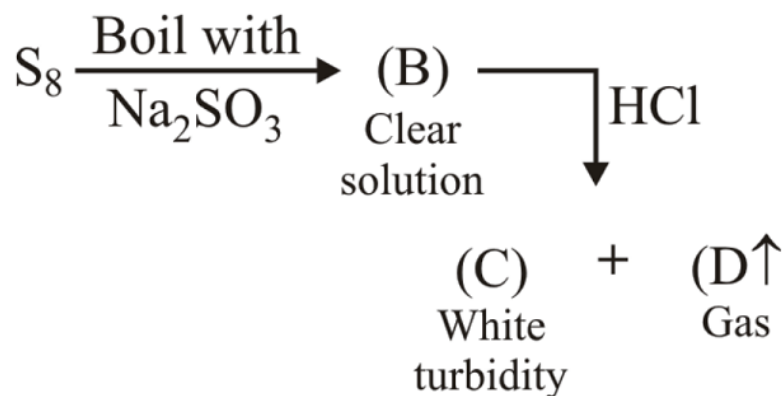

Which of the following is/are correct statements regarding gas (D)?

- A. Hybridisation of gas is sp^2
- B. It can act as oxidising agent
- C. It gives starch-iodate test
- D. It can decolourise KMnO_4

Question No. 2

One or More Options Correct Type

The question has multiple options out of which ONE or MORE is/are correct.

Statement-1 : Net work done by system or on the system lies between 100cal to 200cal.

Statement-2 : Net heat released or absorbed by the system lies between 100 cal to 200cal.

Which of the following graph(s) for one mol of an ideal mono atomic gas is/are satisfying both the statements ($\log 2 = 0.30$, $R = \frac{2\text{cal}}{\text{molK}}$) ?

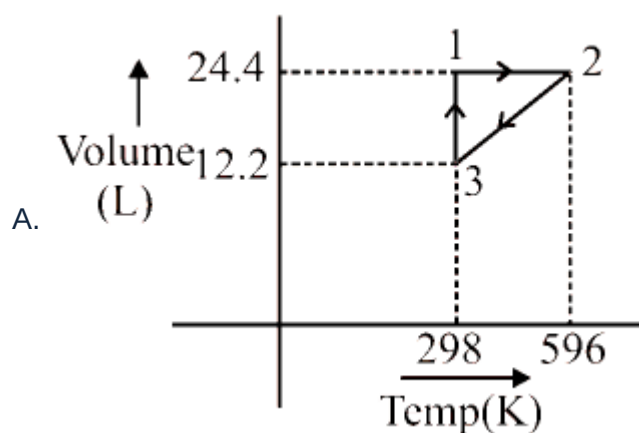

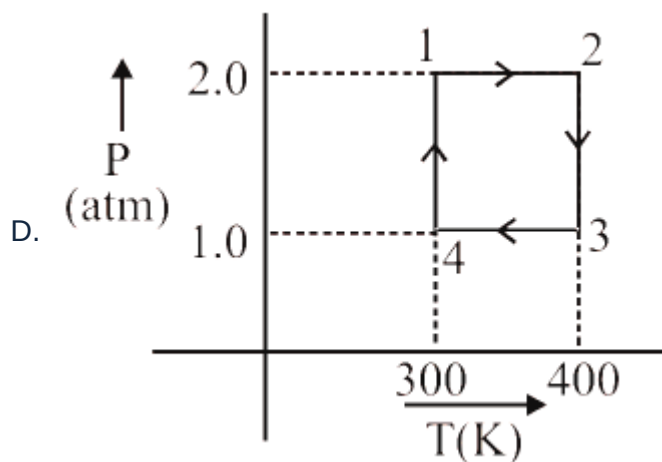
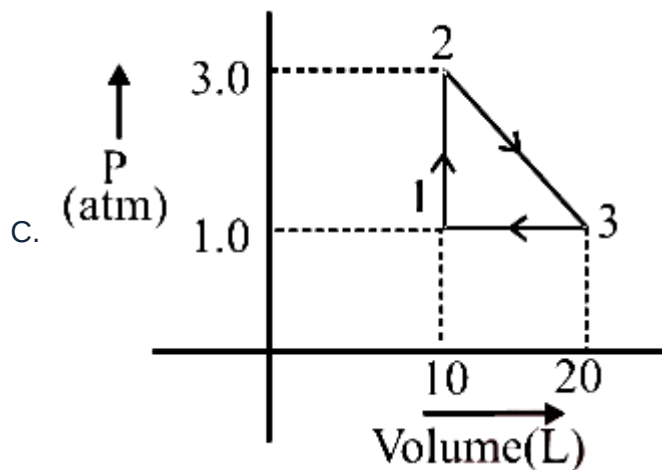
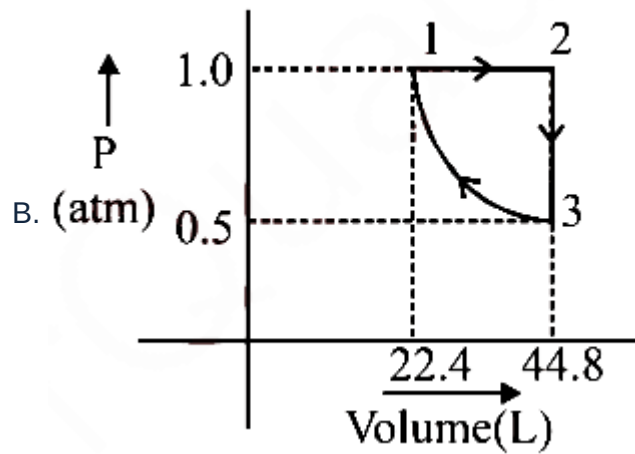

Question No. 3

One or More Options Correct Type

The question has multiple options out of which ONE or MORE is/are correct.

Select the correct options :

Gas is more compressible, if repulsive forces dominate over attractive forces

A. between molecules

B. At extremely low pressure and high temperature, gases behave ideally

C. At Boyle's temperature, gases behave ideally in low pressure region

D. If a gas is kept at $T > T_C$, it can be liquified by lowering pressure alone

Question No. 4

One or More Options Correct Type

The question has multiple options out of which ONE or MORE is/are correct.

A solution contains Na_2CO_3 and NaHCO_3 . 10ml of this solution requires 2.5ml of $\frac{1}{5}$ M HCl solution for the end point using phenolphthalein as indicator. In another experiment 10ml of the same original solution requires 7.5ml of $\frac{1}{5}$ M HCl solution for the end point using methyl orange as indicator. Which of the following statement(s) is/are correct regarding the original solution. [Atomic mass : Na = 23]

- A. 10ml of original solution contains 0.053 g Na_2CO_3
- B. 10ml of original solution contains 0.042 g NaHCO_3 .
- C. Concentration of Na_2CO_3 in original solution 0.05M
- D. Concentration of NaHCO_3 in original solution 0.05M

Question No. 5

One or More Options Correct Type

The question has multiple options out of which ONE or MORE is/are correct.

Irreversible process is :



$$\text{Given at } 0^\circ\text{C} \quad \Delta H_{\text{fusion}} = 6 \text{ kJ/mole}$$

$$\text{at } -10^\circ\text{C} \quad \Delta H_{\text{fusion}} = 5.55 \text{ kJ/ mole}$$

$$C_p(\text{ ice }) = 30 \text{ J/K-mole}$$

$$C_p(\text{ water }) = 75 \text{ J/K-mole}$$

$$\ln \frac{273}{263} = 0.04$$

Pick out the incorrect statements :

- A. ΔS_{total} for process = -20.4 J/K -mole
- B. ΔS_{surr} for process = 21.1 J/K -mole
- C. ΔS_{total} for process = 0.92 J/K -mole
- D. ΔS_{total} for process = 22 J/K -mole

Question No. 6

One or More Options Correct Type

The question has multiple options out of which ONE or MORE is/are correct.

A lead storage cell is discharged which causes the H_2SO_4 electrolyte to change from a concentration of 40% by weight (density = 1.260 gm/ml) to 28%, by weight. The original volume of electrolyte was one litre. Identify the correct statement(s) :-

The overall cell reaction is:

- A. $\text{Pb(s)} + \text{PbO}_2(\text{s}) + 2\text{H}_2\text{SO}_4(\text{aq}) \rightarrow 2\text{PbSO}_4(\text{s}) + 2\text{H}_2\text{O}(\ell)$.
 B. A total of 2.0 moles of H_2SO_4 have reacted.
 C. The total charge released from anode of the cell is 1.93×10^5 coulomb.
 D. The mass of electrolytic solution has decreased.

Question No. 7

One or More Options Correct Type

The question has multiple options out of which ONE or MORE is/are correct.

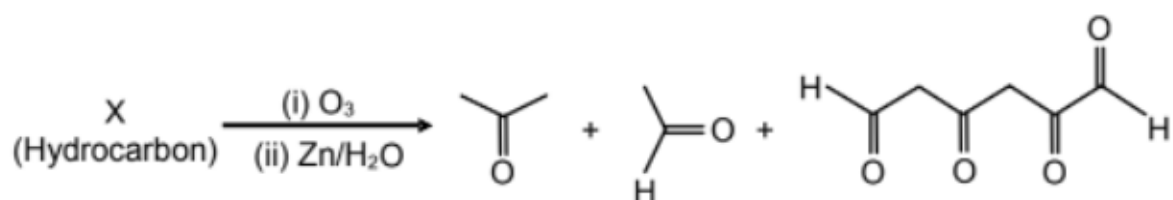

Structures of X can be :

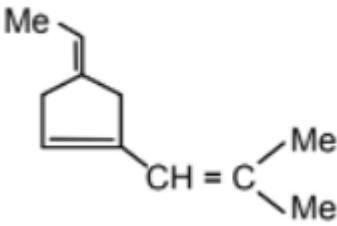
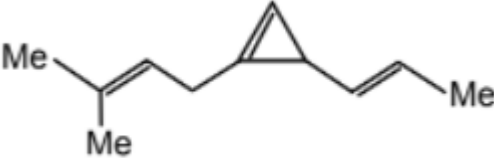
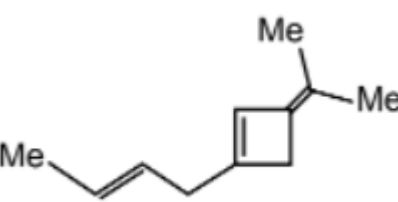
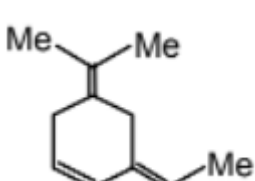
- A. 
- B. 
- C. 
- D. 

Question No. 8

One or More Options Correct Type

The question has multiple options out of which ONE or MORE is/are correct.

Which of the following is / are correctly matched

- A. Teflon - Vinyl fluoride
- B. Natural rubber - chloroprene
- C. Bakelite - Phenol + Formaldehyde
- D. Nylon-6, 6 - Adipic acid + hexamethylene diamine

Chemistry Paragraph Type (Maximum Marks: 12)

Question No. 1

Only One Option Correct Type

Each question has multiple options out of which ONLY ONE is correct.

Paragraph:

(P) and (Q) are isomers of vicinal dicarboxylic acid $C_4H_4O_4$, out of which (P) is more acidic than (Q) towards first ionization.

Question:

The incorrect statement is :

- A. Both (P) and (Q) are stereoisomers
- B. Melting point of (Q) is higher than (P)
- C. Di-sodium salt of both (P) and (Q) gives ethyne on Kolbe's electrolysis
- D. (P) is fumaric acid

Question No. 2

Only One Option Correct Type

Each question has multiple options out of which ONLY ONE is correct.

Paragraph:

(P) and (Q) are isomers of vicinal dicarboxylic acid $C_4H_4O_4$, out of which (P) is more acidic than (Q) towards first ionization.

Question:

The following compounds are formed on reaction of (P) and (Q) with cold alkaline $KMnO_4$.

(P) Cold dil. (S);
Alkaline $KMnO_4$

(Q) Cold dil. (T) + (U)
Alkaline $KMnO_4$

The correct statement regarding above compounds is :

- A. Optically active (S) and optically active pair (T, U)
- B. Optically inactive (S) and optically inactive pair (T, U)
- C. Optically active pair (T, U) and optically active (S)
- D. Optically inactive pair (T, U) and optically active (S)

Question No. 3

Only One Option Correct Type

Each question has multiple options out of which ONLY ONE is correct.

Paragraph:

A sample of 0.4 g powder containing only $X(NO_3)_2$ and $Y(NO_3)_2$ are dissolved in 50 mL water. Ammonia is added to the solution to raise the pH, then an excess of $Na_2C_2O_4$ is added to precipitate the metals almost completely. The precipitate is then filtered off, washed with one litre of water and transferred to a breaker containing 50 mL H_2O . The solution is acidified to solubilize the precipitate and finally titrated with 0.08M $KMnO_4$ solution. A total of 8 mL of oxidizing agent solution was required to reach the end point. K_{sp} of

$XC_2O_4 = 9 \times 10^{-8}$ and of

$YC_2O_4 = 4 \times 10^{-18}$. ($M[X(NO_3)_2] = 250$ g/mol and

$M[Y(NO_3)_2] = 200$ g/mol)

Question:

Which statement about mixture of nitrates is correct?

- A. mmol of $X(NO_3)_2$ taken was 0.4
- B. mmol of $Y(NO_3)_2$ taken was 1.5
- C. mass of $X(NO_3)_2$ taken was 100mg
- D. All the above

Question No. 4

Only One Option Correct Type

Each question has multiple options out of which ONLY ONE is correct.

Paragraph:

A sample of 0.4 g powder containing only $X(NO_3)_2$ and $Y(NO_3)_2$ are dissolved in 50 mL water. Ammonia is added to the solution to raise the pH, then an excess of $Na_2C_2O_4$ is added to precipitate the metals almost completely. The precipitate is then filtered off, washed with one litre of water and transferred to a breaker containing 50 mL H_2O . The solution is acidified to solubilize the precipitate and finally titrated with 0.08M $KMnO_4$ solution. A total of 8 mL of oxidizing agent solution was required to reach the end point. K_{sp} of

$XC_2O_4 = 9 \times 10^{-8}$ and of

$YC_2O_4 = 4 \times 10^{-18}$. ($M[X(NO_3)_2] = 250$ g/mol and

$M[Y(NO_3)_2] = 200$ g/mol)

Question:

Which of the following statements is not correct?

- A. Meq of $KMnO_4$ used in titration is 3.2
- B. The washing of precipitate led to loss of 0.3mmol of oxalate ions
Had titration been carried out in strong alkaline medium volume of
- C. $KMnO_4$ consumed would be 50ml
- D. Had filtrate not been washed 1.5ml of extra oxidant would be consumed

Chemistry Numerical (Maximum Marks: 24)

Question No. 1

Numerical Type

The answer has to be filled into the input box provided below.

A complex compound is represented as $CoCl_3 \cdot xNH_3$. Its 0.1M solution in water shows depression in freezing point equal to 0.558 K. Assuming 100% ionisation of complex and coordination number of Co to be six, calculate the value of '3x'. K_f for H_2O is 1.86 K $kgmol^{-1}$.

Question No. 2

Numerical Type

The answer has to be filled into the input box provided below.

An organic compound ($C_8H_{10}O_2$) rotates plane-polarized light. It produces pink color with neutral $FeCl_3$ solution. What is the total number of all the possible isomers for this compound?

Question No. 3

Numerical Type

The answer has to be filled into the input box provided below.

The 1st, 2nd and the 3rd ionization enthalpies, I_1 , I_2 and I_3 , of four atoms with atomic numbers n , $n + 1$, $n + 2$ and $n + 3$, where $n < 10$, are tabulated below. What is the value of n ?

Atomic number	Ionization Enthalpy (kJ/mol)		
	I_1	I_2	I_3
n	1681	3374	6050
$n + 1$	2081	3952	6122
$n + 2$	496	4562	6910
$n + 3$	738	1451	7733

Question No. 4

Numerical Type

The answer has to be filled into the input box provided below.

Consider the following compounds in the liquid form :

O_2 , HF , H_2O , NH_3 , H_2O_2 , CCl_4 , $CHCl_3$, C_6H_6 , C_6H_5Cl .

When a charged comb is brought near their flowing stream, how many of them show deflection as per the following figure?

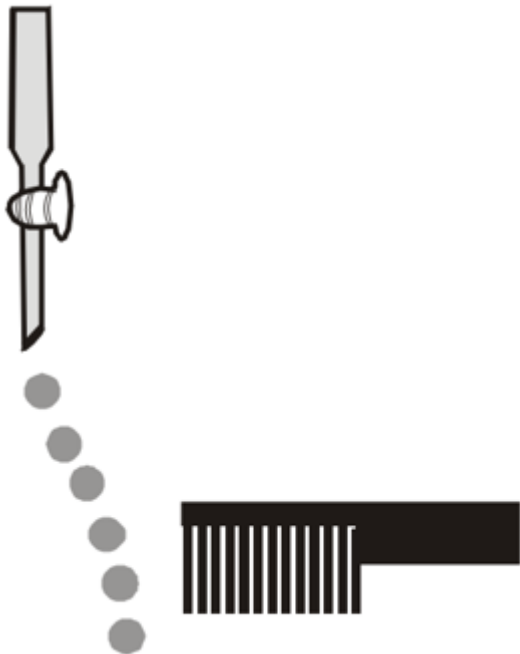

Question No. 5

Numerical Type

The answer has to be filled into the input box provided below.

Write the sum of the oxidation number of metal in products of given reactions :-

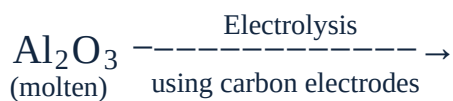
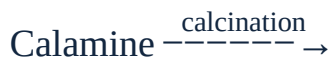

Question No. 6

Numerical Type

The answer has to be filled into the input box provided below.

Consider the adjoining structure. The number of halogen atoms that

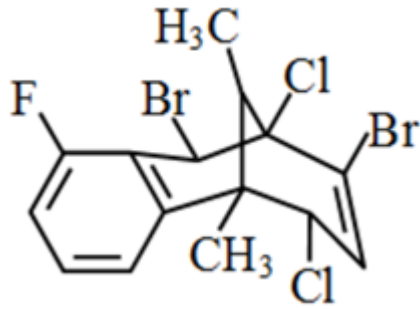

(a) can form Grignard reagent on addition of Mg is (P).

(b) can produce a precipitate with aq. AgNO_3 is (Q).

(c) can give a predominant $\text{S}_{\text{N}}2$ substitution reaction with KCN is (R).

Find $(P + Q + R)$.

Mathematics Multiple Correct (Maximum Marks: 32)

Question No. 1

One or More Options Correct Type

The question has multiple options out of which ONE or MORE is/are correct.

If $f(x) = 2 + \int_{-1}^1 \left(\frac{tx^2}{2} + \frac{9x}{14} \right) f(t) dt$, then:

- A. Rolle's Theorem is applicable for $y = f(x)$ in $[-2, -1]$
- B. $\lim_{x \rightarrow 0} f(x) = 0$
- C. f is continuous and derivable on R
- D. maximum value of $f(x)$ does not exist

Question No. 2

One or More Options Correct Type

The question has multiple options out of which ONE or MORE is/are correct.

Let $E - ABCD$ be a pyramid on square base $ABCD$ where A is the origin and B and D are lying on positive x -axis and y -axis respectively. If E is $(0, 2, 3)$ and $\overline{DE} \cdot (\hat{i} + \hat{j}) = \vec{0}$, then:

- A. image of the point D in the plane ABE is $(0, \frac{-10}{13}, \frac{24}{13})$

B. image of the point D in the plane ABE is $(0, \frac{-6}{13}, \frac{30}{13})$

C. volume of the tetrahedron $ABDE$ is 2 cubic units

D. perpendicular distance of the point D from the plane ABE is $\frac{9}{\sqrt{13}}$

Question No. 3

One or More Options Correct Type

The question has multiple options out of which ONE or MORE is/are correct.

Consider a cube of side length 9 units. Let (x, y, z) be coordinates of points on or inside the cube such that $x, y, z \in I$ and $0 \leq x, y, z \leq 9$. If total number of ways of selecting two distinct points among these such that their mid-point is also having integral coordinates is N , then

A. N is divisible by 30

B. N is divisible by 31

C. N is divisible by 32

D. Number of factors of N is 40

Question No. 4

One or More Options Correct Type

The question has multiple options out of which ONE or MORE is/are correct.

The values of ' t ' which satisfies $(t - \lceil \sin x \rceil)! = 3!5!7!$ is/are (where $\lceil \cdot \rceil$ denotes greatest integer function) -

A. 9

B. 10

C. 11

D. 12

Question No. 5

One or More Options Correct Type

The question has multiple options out of which ONE or MORE is/are correct.

Let $f : R \rightarrow (0, 1)$ be a continuous function, then which of the following pair of vectors are linearly dependent for some $x \in (0, 1)$?

A. $\vec{a} = f(x)\hat{i} + 2\hat{j}; \vec{b} = x^2\hat{i} + 3\hat{j}$

B. $\vec{a} = f(x)\hat{i} + 3\hat{j}; \vec{b} = x^2\hat{i} + 2\hat{j}$

C. $\vec{a} = (\int_0^{1-x} f(t)dt)\hat{i} + 3\hat{j}; \vec{b} = x\hat{i} + 2\hat{j}$

D. $\vec{a} = (\int_0^{1-x} f(t)dt)\hat{i} + 2\hat{j}; \vec{b} = x\hat{i} + 3\hat{j}$

Question No. 6

One or More Options Correct Type

The question has multiple options out of which ONE or MORE is/are correct.

The curve(s) which satisfy the differential equation $xdy = ydx + \sin(\frac{1}{x})dx$ can be

- A. $y = x(\cos(\frac{1}{x}) + 3)$
- B. $y = 2x(2\cos^2(\frac{1}{2x}) + \sin^2(\frac{1}{2x}))$
- C. $y = x^2(\cos(\frac{1}{x}) + 3)$
- D. $y = 2x(2\cos^2(\frac{1}{2x}) - \sin^2(\frac{1}{2x}))$

Question No. 7

One or More Options Correct Type

The question has multiple options out of which ONE or MORE is/are correct.

If $f(x) + f(y) = \frac{1}{x} + \frac{1}{y}$, $\forall x, y \in \mathbb{R} - \{0\}$ and $\int_2^3 \frac{3(f(x))^5 - f(x)}{1 - (f(x))^4} dx = \frac{1}{2} \log \frac{2^\alpha}{3^\beta}$, then

- A. $\alpha > \beta$
- B. β is prime
- C. $\alpha < 2\beta$
- D. $(\alpha + \beta)$ is prime

Question No. 8

One or More Options Correct Type

The question has multiple options out of which ONE or MORE is/are correct.

Number of terms in the expansion of $(1 + y + \frac{1}{y})^n$ is 21601, then which of the following are correct?

- A. number of divisors of n which are multiple of 12 is 27
number of ways in which $\frac{n}{100}$ distinct objects can be given to 3 persons
- B. equally are $\frac{100!}{(10!)^{10}}$
- C. exponent of 7 in $(\frac{n}{100})!$ is 17
number of triangles joining the points of intersection of $\sqrt{\frac{n-800}{10}}$ straight lines (no two of which are parallel and no three of which are concurrent) is
- D. ${}^{45}C_3 - {}^{44}C_3$

Mathematics Paragraph Type (Maximum Marks: 12)

Question No. 1

Only One Option Correct Type

Each question has multiple options out of which ONLY ONE is correct.

Paragraph:

Consider a parabola, $y^2 = 4ax$ then $y + tx = at^3 + 2a$ represents a normal at a point $(at^2, 2at)$. It can also be represented as $y - mx + am^3 + 2am = 0$ in its slope form.

Considering the above equation and assuming it passes through a point $P(h, k)$ we can say that $k - mh + am^3 + 2am = 0 \Rightarrow am^3 + m(2a - h) + k = 0$ from $P(h, k)$ maximum 3 normals can be made to the parabola $y^2 = 4ax$

Question:

Consider a point $P(x_1, 0)$ lying inside the parabola $y^2 = 4ax$ then the interval of x_1 such that only one normal passes through P is

- A. $(0, 8a)$
- B. $(0, 2a)$
- C. $(0, 4a)$
- D. none of these

Question No. 2

Only One Option Correct Type

Each question has multiple options out of which ONLY ONE is correct.

Paragraph:

Consider a parabola, $y^2 = 4ax$ then $y + tx = at^3 + 2a$ represents a normal at a point $(at^2, 2at)$. It can also be represented as $y - mx + am^3 + 2am = 0$ in its slope form.

Considering the above equation and assuming it passes through a point $P(h, k)$ we can say that $k - mh + am^3 + 2am = 0 \Rightarrow am^3 + m(2a - h) + k = 0$ from $P(h, k)$ maximum 3 normals can be made to the parabola $y^2 = 4ax$

Question:

The area of the region inside the parabola $y^2 = 4ax$ from which only one normal can be drawn is

- A. $\frac{352\sqrt{2}a^2}{15}$
- B. $32\sqrt{2}a^2$
- C. $\frac{48\sqrt{2}a^2}{5}$

D. none of these

Question No. 3

Only One Option Correct Type

Each question has multiple options out of which ONLY ONE is correct.

Paragraph:

A and B are playing a badminton match with the agreement that winner of each set will get 1 point and the loser 0 point. The match ends as soon as one of them is ahead by 2 points or number of sets reaches six. It is supposed that the probabilities of A and B winning a set are $\frac{2}{3}$ and $\frac{1}{3}$ respectively and each set is independent.

Let X_i denotes the event that atleast i sets are played and Y and Z denotes the event that match has won by A and B respectively.

Question:

Identify incorrect option -

A. $P\left(\frac{Y}{X_5}\right) = \frac{4}{9}$

B. $P\left(\frac{Z}{X_4}\right) = \frac{13}{81}$

C. $P(X_{2k-1}) = P(X_{2k}) \forall k \in \{1, 2, 3\}$

D. $P\left(\frac{Z}{x_1}\right) = \frac{64}{729}$

Question No. 4

Only One Option Correct Type

Each question has multiple options out of which ONLY ONE is correct.

Paragraph:

A and B are playing a badminton match with the agreement that winner of each set will get 1 point and the loser 0 point. The match ends as soon as one of them is ahead by 2 points or number of sets reaches six. It is supposed that the probabilities of A and B winning a set are $\frac{2}{3}$ and $\frac{1}{3}$ respectively and each set is independent.

Let X_i denotes the event that atleast i sets are played and Y and Z denotes the event that match has won by A and B respectively.

Question:

If it is known that A has won the third set then probability that A will win the match is equal to

- A. $\frac{4}{9}$
- B. $\frac{13}{18}$
- C. $\frac{22}{27}$
- D. $\frac{76}{81}$

Mathematics Numerical (Maximum Marks: 24)

Question No. 1

Numerical Type

The answer has to be filled into the input box provided below.

If number of points of discontinuity of the function $f(x) = [2 + 10 \sin x]$, in $x \in [0, \frac{\pi}{2}]$ is same as number of points of non-differentiability of the function $g(x) = (x - 1)(x - 2)|(x - 1)(x - 2) \dots (x - 2m)|$, (where $m \in N$) in $x \in (-\infty, \infty)$. The value of m is, (where $[.]$ denotes the greatest integer function)

Question No. 2

Numerical Type

The answer has to be filled into the input box provided below.

Let $S_n = \sum_{x=1}^n x!$; $n \geq 6$, $T = \arcsin(\sin(S_n - 7[\frac{S_n}{7}]))$. If $\int_0^1 \frac{T}{\sqrt{1-x^2}} dx = \frac{a\pi}{b} - \pi^c$ where $a, b, c \in W$; $b \neq 0$, then find $(\frac{b}{c} + a)$.

Question No. 3

Numerical Type

The answer has to be filled into the input box provided below.

Let $D = \begin{bmatrix} 1 & 0 & 0 \\ 0 & 2 & 0 \\ 0 & 0 & 3 \end{bmatrix}$ and $P = \begin{bmatrix} 7 & 0 & 2 \\ 0 & 1 & 0 \\ 2 & 0 & 5 \end{bmatrix}$. Consider $A = P^{-1}DP$. Find $\det. (A^2 + A)$

Question No. 4

Numerical Type

The answer has to be filled into the input box provided below.

Given two curves : $y = f(x)$ passing through $(0, 1)$ and $y = \int_{-\infty}^x f(t)dt$ passing through $(0, \frac{1}{3})$. The tangents drawn to both the curves at the points with equal abscissas intersects on x -axis. Find the value of $\ln f(3)$

Question No. 5

Numerical Type

The answer has to be filled into the input box provided below.

$$\text{If } f(x) = \frac{\sin^{-1}\left(\frac{x}{10C_x}\right) + \cos^{-1}\left(\frac{x}{10C_x}\right)}{\sqrt{5[x]^2 + 6\{x\}^2 - 60[x] + 77\{x\} + 160}}, \text{ (where } [.] \text{ denotes the GIF and } \{.\} \text{ denotes the fractional part)}$$

then number of integers in domain of $f(x)$ is:

Question No. 6

Numerical Type

The answer has to be filled into the input box provided below.

Let λ is the coefficient of x^2 in the expansion $(1 + x)(1 - 3x)(1 + 5x)(1 - 7x) \dots (1 - 23x)(1 + 25x)$ then number of positive divisors of $|\lambda|$ is